

N NARGESA®

PROPANE FORGING FURNACE

H1

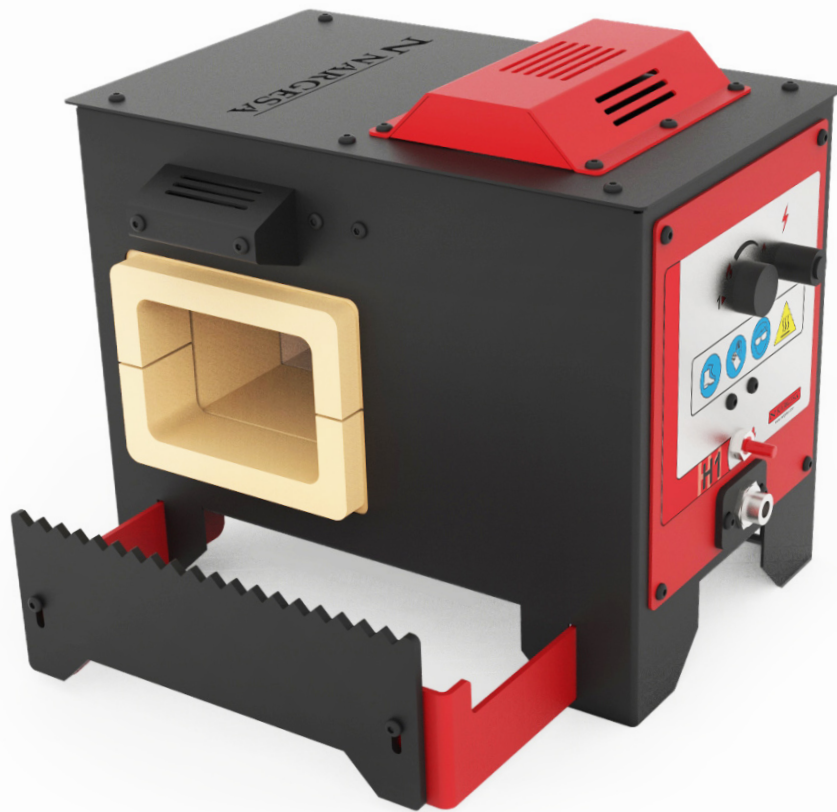

+ than 40 years
manufacturing industrial machinery

Forging Furnaces Nargesa are used in blacksmiths workshops for ornamental forge, moulding iron up to achieving the desired shapes.

REQUEST QUOTATION

Please fill up the following form. We will contact you in less than 24 hours.
Working days

VIDEO MACHINE OPERATION

Machine performance video

If you're looking for a clean, safe flame which makes you turn steel into its red hot point so you can shape it, the Propane Furnace Nargesa is the one. It will be for sure your best choice!



Horseshoes



Forging decoration



Knives
Swords
Axes

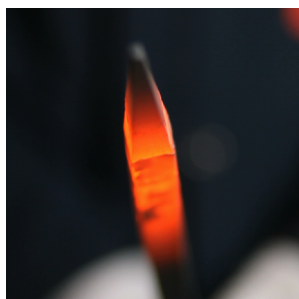

All sort of designs for artistic forging



Iron garden furniture

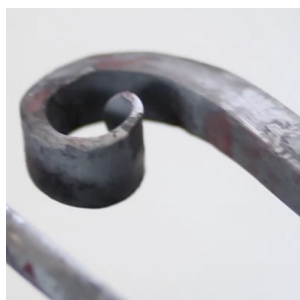

Sculptures in iron



Wrought iron chairs and tables

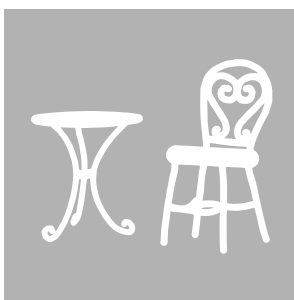

It is a good substitute for the old Forge, much cleaner, faster and more efficient

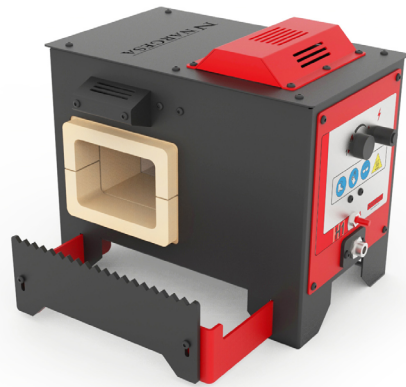

H1
1 BURNER

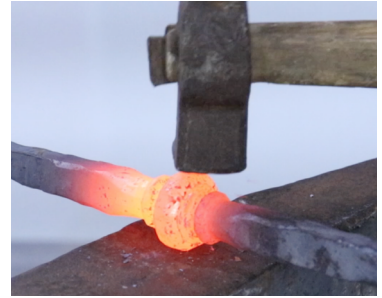
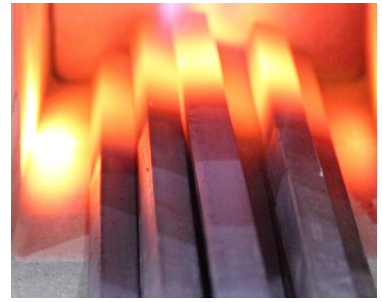

H2
2 BURNERS



H3
3 BURNERS

PROPANE FORGING FURNACES

NEW Propane forging furnaces Nargesa are equipped with one, two or three burners to heat the iron and work it: moulding, bending, piercing, welding, tempering, forging, shoeing horses...



SAFER

It has got new security systems for the operator. Fulfilling the regulation RD919/2006. Certified by the Technological Center APPLUS, General Laboratory for Testing and Investigation.



MORE EFFICIENT

Consume up to 75% less gas and reach a higher temperature than any oven in its category. More than 1300°C.



RESPECTFUL WITH THE ENVIRONMENT

Emissions below 0.002% of CO. Internal vermiculite coating, 100% natural and recyclable.



SAFETY OF THE OPERATOR

The safety of the operator is one of the main premises when designing all Nargesa machines. The H1 forging furnace has got all the necessary safety devices for the well-being of the operator that will handle it and it is according to the Regulation of appliances that use gas as fuel RD919 / 2006.

Automatic electronic ignition

Prevents the operator from inserting his hands in the combustion chamber to turn on the gas. No tool is necessary to generate the spark.

Gas system integrated in the oven structure

The components were totally protected from impacts that could damage and cause leaks.

Insulation of the combustion chamber

These elements are formed by a 100% natural material, compacted vermiculite, not harmful to health. 100% recyclable as it does not include glass fibers or ceramics.

Thermocouple safety valve

This device closes the passage of the gas when the combustion chamber cools due to an anomaly, avoiding any possible leak.

Anti-return valve

This valve regulates the direction of the gas flow preventing it from being addressed to the cylinder.



ENERGY EFFICIENCY

Saving energy is another topic that our R & D department takes into account for the furnace.

Fuel consumption

The consumption of Nargesa furnaces has been reduced in a 75%, that is to say, it consumes 1/4 of the fuel used by the same furnaces in its category. With a LPG propane gas cylinder of 35Kg, the H1 Furnace will operate 100 hours.

Gas losses

There is no fuel, all the propane gas that enters the combustion chamber burns, without any sort of waste. This process has been possible due to the new burners, which have been designed and manufactured by Nargesa.



RESPECT FOR THE ENVIRONMENT

It is totally infeasible to manufacture machinery and not to take into consideration the planet we inhabit.

New generation insulating material

The insulating material of the combustion chamber, the compacted vermiculite, is a 100% recyclable material and does not generate waste, increasing the heating (thermic) power of the cavity, over 1300°C.

CO Emissions

The emissions emitted by the furnace are 0.002%. In normal environment this value is between 0 and 2. Certified by the General Laboratory of Tests and Investigations: APPLUS Technology Center.



TECHNICAL FEATURES

Painting

The furnace is covered with heat painting to protect.

Insulation of vermiculite

Double insulation of compacted vermiculite, to avoid heat loss. Insulating flange in the material inlets to keep the heat inside the combustion chamber.

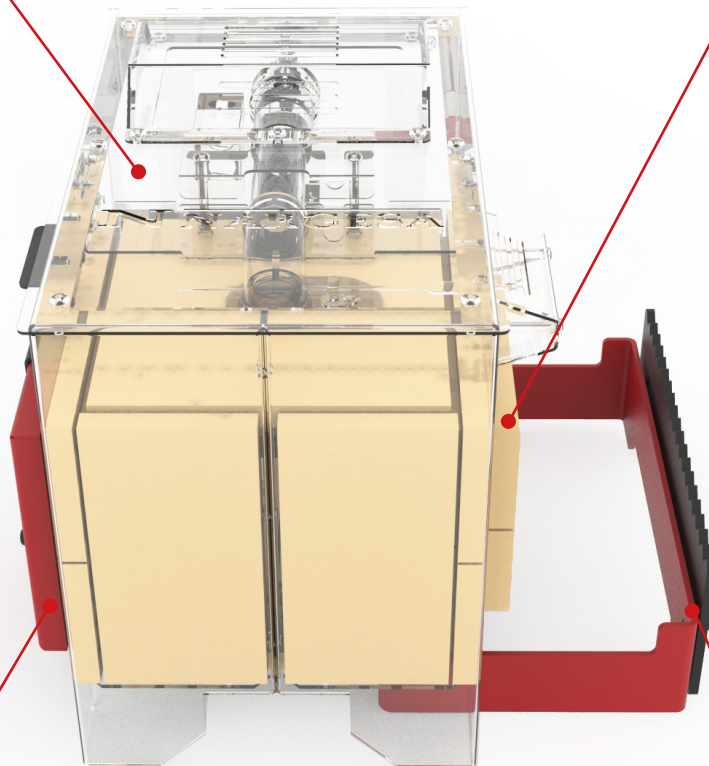

Removable rear door

To work in the center of the iron bars. The door are installed without using tools.

Integrated bar support and adjustable to the different lengths of material

Its shape prevents the material from sliding laterally. Possibility to place the material support in any of the two entries.

All components are standard and easy to find in any warehouse or hardware store

Air flow regulator

To adjust this size to the different altitudes. Depending on the work place of the furnace and its altitude regarding the sea, the air flow for the mixture of gas and marine air will be regulated, the suitability for a good combustion.

Needle flow regulation valve

Allow the accurate regulation of gas flow.

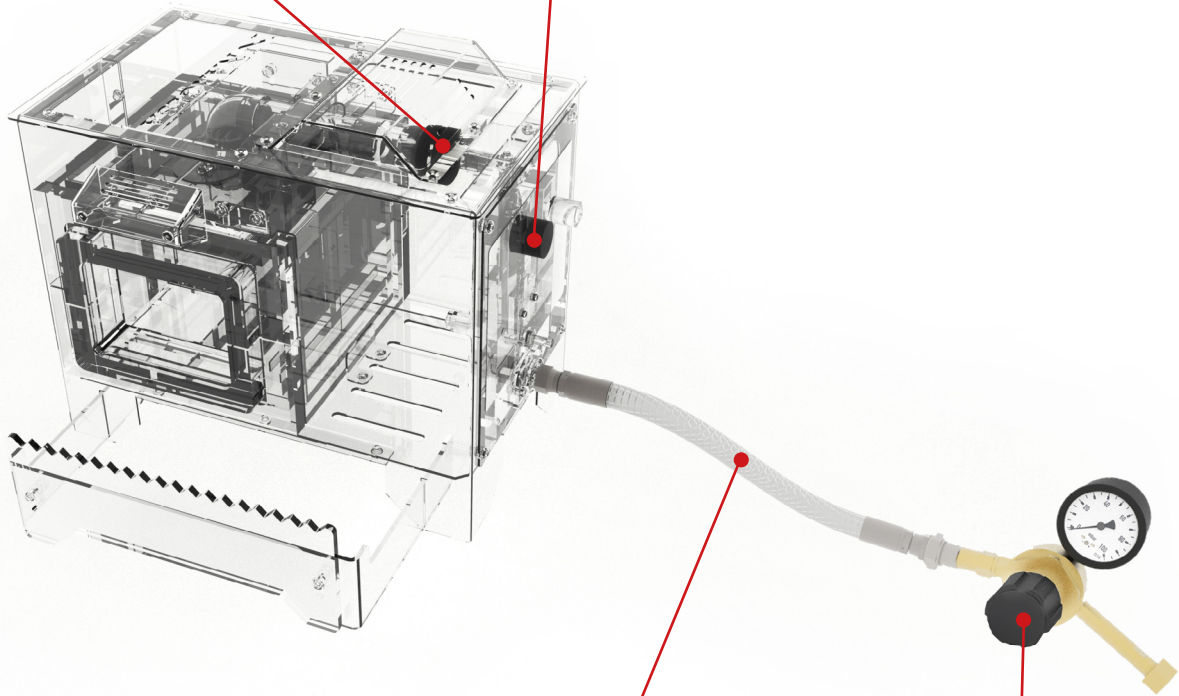

Gas hose made of stainless steel

This characteristic prevent it from collapsing and burning. This hose does not expire, so it is not necessary to replace it.

Precision pressure regulator with built-in pressure gauge

Allows to adjust the gas pressure more precisely.

To regulate the performance of Furnace H1 we have a control panel that enables us to keep the whole operation of the machine in a simple and intuitive way

Gas valve

The Control panel has got one valve for the opening of the gas entrance to the Burner. The operator controls them in order to obtain more or less gas flow.

Electronic switching

Is the one that activates the spark plug and generates the spark to light up the Burner.

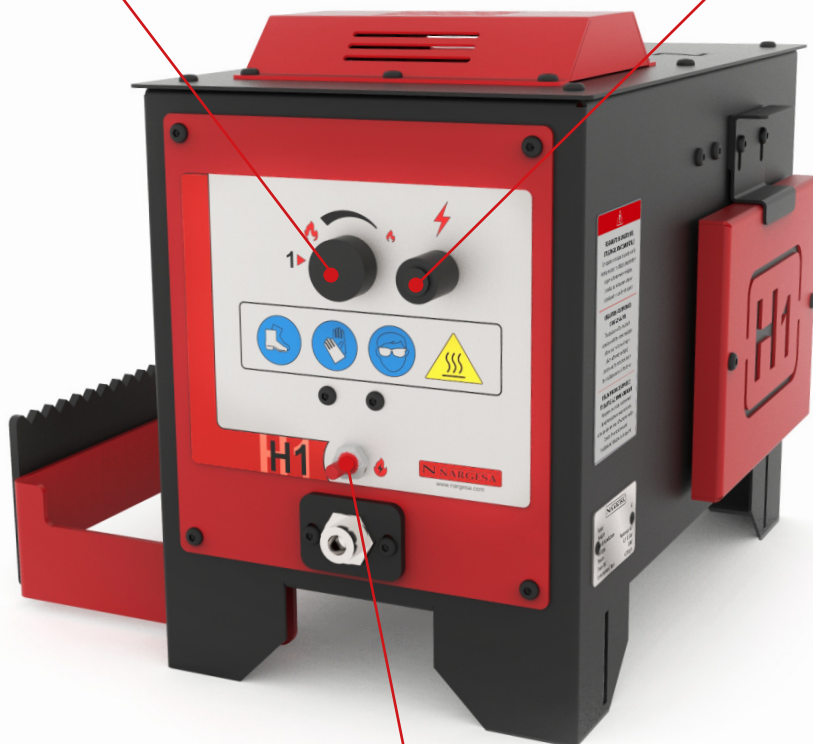

Thermocouple push-button

Is the one that opens the valve to get the thermocouple activated. This valve opens the path to the Gas valves

DETAILED FEATURES



H1

Fuel type
Adjustable working pressure
External dimensions
of combustion chamber
Weight

Propane gas (GLP)
0.1 - 1.5 bar
430x320x364 mm Size
140x236x100 mm We
26 Kg



H2

Fuel type
Adjustable working pressure
External dimensions
Size of combustion chamber
Weight

Propane gas (GLP)
0.1 - 1.5 bar
440x500x364 mm
324x240x100 mm
38 Kg



H3

Fuel type
Adjustable working pressure
External dimensions
Size of combustion chamber
Weight

Propane gas (GLP)
0.1 - 1.5 bar
580x500x364 mm
464x240x100 mm
50 Kg

Maximum temperature



Number of burners



Power (Hi)



Gas intake as 1 per bar
x 1 burner
x 2 burners
x 3 burners



EXTERNAL DIMENSIONS

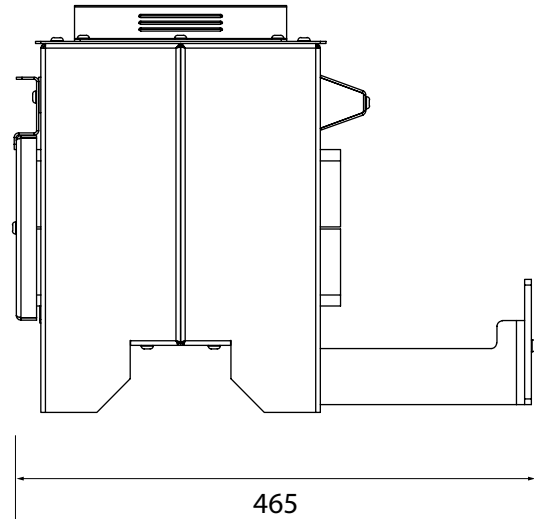
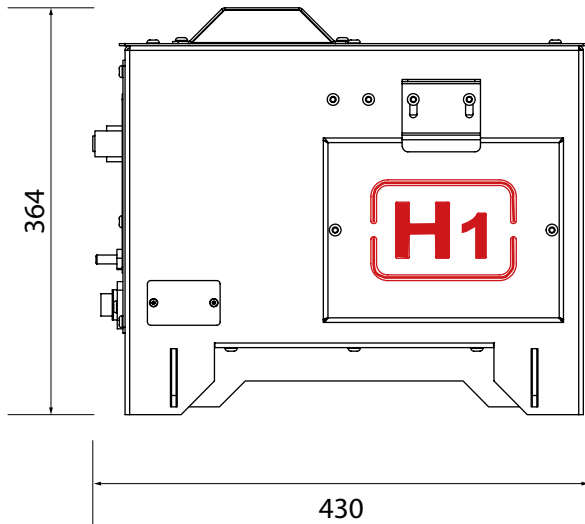

CHARACTERISTICS OF THE PACKAGING

- Tariff Item Code: 84178080
- Gas furnace is delivered completely mounted.
- Complete wooden packaging NIMF15.

H1

Width	600 mm
Length	400 mm
Height	590 mm
Volume	0,142 m ³
Nett weight	27 Kg
Gross weight	33 Kg

OUR RANGE OF MACHINERY



IRON WORKERS



SECTION BENDING
MACHINES



NON-MANDREL PIPE BENDER



HORIZONTAL PRESS BRAKES



TWISTING/SCROLL BENDING
MACHINES



HYDRAULIC PRESS BRAKES



HYDRAULIC SHEAR
MACHINES



GAS FORGES



IRON EMBOSSING MACHINES



END WROUGHT IRON
MACHINES



BROACHING MACHINES



POWER HAMMERS



PRESSES FOR LOCKS

WARRANTY

Nargesa machines have 3 years warranty provided that the customer registers it in our website. Otherwise it would be only one year warranty. This one encloses any manufacturing default all along these 3 years for components. Any misuse is excluded from this condition. Labor, back and forth shipping and any eventual repair, are not included in this warranty.

Partner companies



Airpharm

SHIPMENT EVERYWHERE

Nargesa will arrange transport up to final destination, whenever the customers asks for so. There is also the possibility for the customer to arrange the shipment himself with his own agency.

TECHNICAL ASSISTANCE

All our customers have access to technical support quickly and efficiently.

90% of incidences are solved out on the phone, mail, Skype or videoconferencing in less than 24hours. In case of needing presencial technical assistance, we may as well send a technician to the customer's facilities.

Follow us on

PRADA NARGESA, S.L.

Ctra. De Garrigàs a Sant Miquel s/n
17476 Palau de Santa Eulalia (Girona) Spain

Tel. +34 972 568 085

www.nargesa.com

nargesa@nargesa.com

This information might undergo changes